

fireframes
SG Curtainwall® Series

45-MINUTE FIRE-RATED



Technical Glass Products Architectural Specification Manual

Patent No. 8,567,142

800.426.0279 | fireglass.com

TGP  **FIRE RATED**
one source. many solutions.®

FIREFRAMES SG CURTAINWALL SERIES

With the Fireframes SG Curtainwall® Series, design professionals can now create large, fire-rated glazed walls with the smooth, monolithic appearance of a structural silicone glazed system. The patented, fire-rated toggle glazing system allows for rapid installation of fire-rated Pilkington Pyrostop® glass while being completely hidden once installed. These features, combined with narrow steel frames allow high strength, clean sightlines and up to 120 minutes of fire resistance. Fireframes SG Curtainwall Series is just one of the many expressions of creativity that are changing traditional thinking about fire-rated glass and framing. The future of fire safety has never looked so good.

For specifications, photographs and additional information contact:

Technical Glass Products
8107 Bracken Place SE
Snoqualmie, WA 98065

Office: 800.426.0279
425.396.8200

Fax: 800.451.9857
425.396.8300

E-mail: sales@fireglass.com

Web: fireglass.com

System Exploded Assembly

ITEM	DESCRIPTION	ITEM	DESCRIPTION	ITEM	DESCRIPTION
1	ANCHOR	9	SPACER, VERTICAL PERIMETER	17	MULLION, INTERMEDIATE HORIZONTAL
2	MULLION, PERIMETER VERTICAL	10	#6-20 X 1/2 PH SHEET METAL SCREW	18	SLIDING SHEAR CLIP
3	GASKET	11	MULLION, INTERMEDIATE VERTICAL	19	GLAZING PLATFORM, BOLT-ON
4	GASKET	12	MULLION, PERIMETER HORIZONTAL	20	SETTING PAD
5	CLIP, PERIMETER SPACER	13	SLIDING SHEAR CLIP	21	T-JOINT CONNECTING PLATE 45 mm
6	M5 M-F 8MM STANDOFF	14	GLAZING PLATFORM, BOLT-ON SILL	22	X-JOINT CONNECTING PLATE 60 mm
7	TOGGLE	15	M6x1x30mm FHSC SCREW	23	SCREW, SELF-DRILLING
8	M5x0.8 x 12 mm BHSC SCREW	16	SPACER, HORIZONTAL PERIMETER	24	PYROSTOP IGU w/INTUMESCENT TAPE
				25	TRIM, PERIMETER

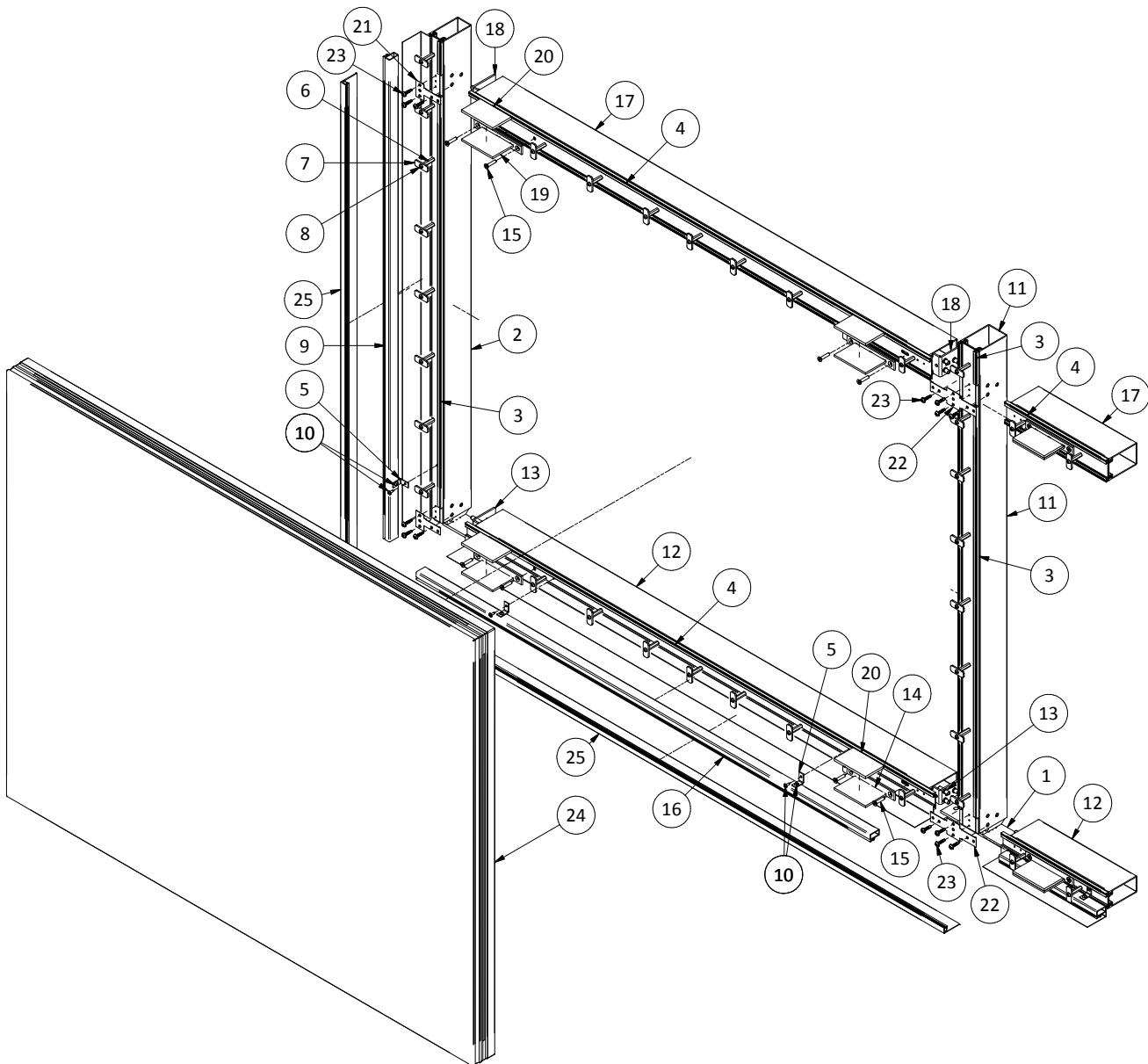

Figure 1: System Exploded Assembly

General Information

GENERAL INFORMATION

The Fireframes SG Curtainwall Series revolutionizes fire-rated framing. Incorporating precise European engineering, the patented Fireframes SG Curtainwall Series allows for large, multi-story expanses of glass for interior or exterior applications. Now fabricated in the United States, Fireframes SG Curtainwall Series frames are classified and labeled with UL and ULC.

Contact TGP with questions concerning these details as they apply to the particulars of a given project.

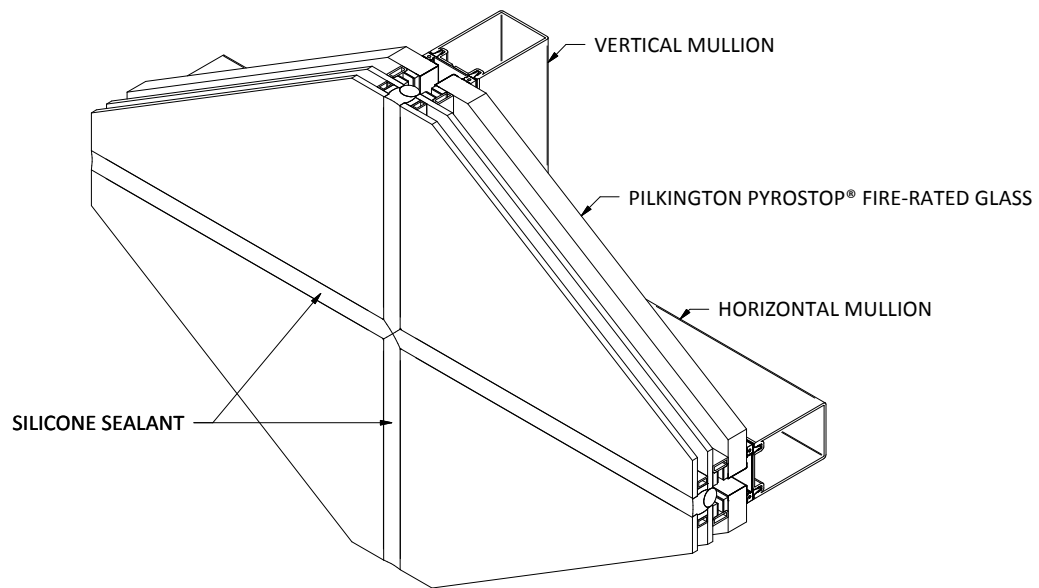

Figure 2. System Overview

General Information

FEATURES

- Fire ratings of 45, 60 and 120 minutes
- 60 and 120 minute ratings allow unrestricted glazing area for use in locations where total glazing exceeds 25% of wall
- Full-lite doors available in single leaf or double leaf design (see Fireframes® Designer Series or Fireframes Heat Barrier Series)
- Air and water pressure tested and approved for exterior use
- Durable steel frames ensure low maintenance system
- Narrow steel profiles
- Silicone sealed for smooth monolithic appearance, no pressure plates or caps
- Shear block fabrication system
- Easy installation using unique toggle retention system, patent no. 8,567,142
- Frames supplied “K.D.” (knock-down)
- Frame finished at the factory to match desired color scheme
- Available in 2-sided and 4-sided systems; 2-sided systems have snap-on covers to conceal pressure plate screws
- Fabricated in the U.S.A.

General Information

LISTINGS

- Classified and labeled by Underwriters Laboratories, Inc.® and Underwriters Laboratories of Canada. Covered under UL File No. R-25229 for fire door and window frames with 45 & 60 minutes ratings.
- Frame tests performed in accordance with UL 9, ASTM E2010, NFPA 257. If your jurisdiction requires "barrier to heat" framing according to test standards ASTM E-119 or UL 263, please see our Fireframes SG Curtainwall Series rated 60 or 120 minutes.

SIZING GUIDELINES

Frame Rating	Maximum Exposed Glass Area Per Frame	Maximum Exposed Glass Single Dimension	Maximum Frame Size
45 minutes	31.25 sq. ft. (4,500 sq. in.) 2.9 m ²	95 1/4" 2419 mm	120" X 120" 3048 mm x 3048 mm

PILKINGTON PYROSTOP® FIRE-RATED GLAZING OPTIONS

Technical Glass Products provides Pilkington Pyrostop® fire-rated glazing options to complement the Fireframes SG Curtainwall Series.

SPECIFICATIONS

Manufacturer's Designation	45-260 FG	45-360 FG
Fire Rating (minutes)	45	45
Glazing Type	IGU	IGU
Application	Interior * Opening Protective	Exterior * Opening Protective
Nominal Thickness	2-1/2" 63.7 mm	2-1/2" 63.7 mm
Weight - Pounds per Square Foot (approx.)	15 lbs/ft ² 73.24 kg/m ²	15 lbs/ft ² 73.24 kg/m ²
Daylight Transmission (approx.)	N/A	N/A
STC Rating (dB) (approx.)	N/A	N/A

Recommended Guidelines

1. BUILDING CODES

Due to the diversity in local, state / provincial, or federal laws and the codes that govern design and application of architectural products, it is the responsibility of the individual architect / owner and installer to assure that products selected for use on projects comply with all the applicable building codes and laws. Technical Glass Products exercises no control over the use or application of its products, glazing materials, and operating hardware and assumes no responsibility thereof. Compliance of TGP project drawings with applicable codes for a given project shall be the responsibility of the TGP customer.

2. COORDINATION WITH OTHER TRADES

Coordinate with the general contractor any sequence with other trades which impact curtain wall installation (i.e. fire proofing, back-up walls, partitions, ceilings, mechanical ducts, converters, etc.) or in which curtain wall installation may impact the work of adjacent trades.

3. INSTALLATION

All materials are to be installed true, plumb and level.

4. BENCHMARKS

All work should start from bench marks and /or column lines as established by the architectural drawings and the general contractor with guaranteed accuracy. Using these datum points and lines, determine:

- a. The plane of the wall in reference to offset lines provided on each floor;
- b. The finish floor lines in reference to bench marks on the outer building columns; and
- c. Mullion spacing from both ends of masonry openings to prevent dimensional build-up of daylight opening.

5. SURROUNDING CONDITIONS

- a. Coordination of adjacent material and construction tolerances to TGP's systems may be facilitated by TGP as part of preparing project drawings, and these drawings may indicate acceptable tolerances for critical dimensions. The installer should verify that surrounding construction is in accordance with the approved project drawings. Do not accept rough opening dimensions less than shown on project drawings. It is assumed that the minimal joint dimensions shown on the TGP project drawings match the field conditions. A frame may fit within a given opening but sealants may not perform as detailed if a smaller sealant joint is installed. Expansion / contraction issues may also be compromised. **IF THE JOINTS ARE SMALLER THAN THAT SHOWN ON THE TGP PROJECT DRAWINGS, DO NOT PROCEED.** Notify the General Contractor that the conditions are not as detailed and wait for corrective work to be completed before starting this work.
- b. The installer **MUST** notify and receive approval from TGP and the general contractor when conditions are not in accordance with approved project drawings and/or change any aspect of the structural performance of the Fireframes system before making any modifications to the TGP-furnished material or making changes which are different from those shown on the TGP project drawings. These conditions include, but are not limited to, anchor placement/location, changes in adjacent materials the anchor is

Recommended Guidelines

being connected to or changes to dimensional relationships between framing, anchors and connection to adjacent materials.

- c. TGP must review and approve any changes required prior to the subcontractor installing any “corrective” work. These reviews may incur additional charges, which must be approved by the TGP customer prior to TGP’s review.

6. FRAME CONSTRUCTION VARIES

- a. As a standard, most frames are shipped “K-D” (knock-down) and are to be assembled on site. Depending on the size and/or the manufacturer's preference, some curtain wall components may be pre-assembled or welded in the factory. Figure 3 shows the typical elevation of a curtain wall frame construction.
- b. Some pre-assembly of the frames prior to installation on site is possible. **TGP does not pre-assemble/ unitize frames prior to shipment, as the method for doing so is not intended for long shipping distances.**
- c. Sill anchors, mullion splices and accessories (when required) are generally welded to the vertical frames at the factory.

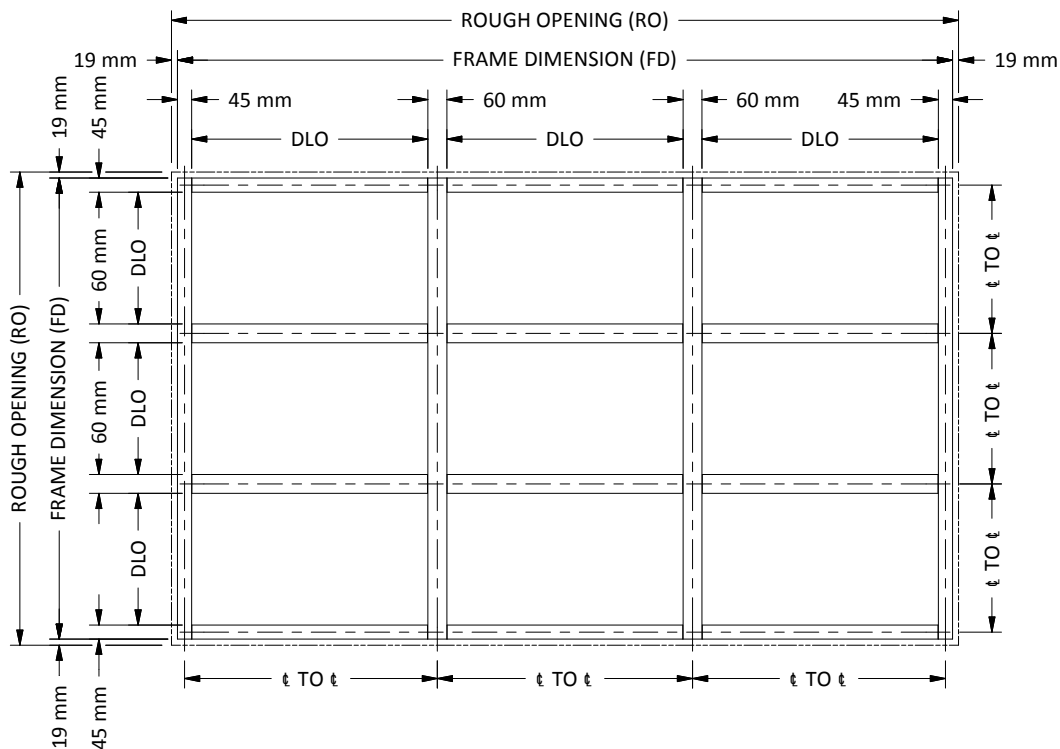

Figure 3: Typical Fireframes Frame Elevation

Recommended Guidelines

7. FASTENING

Within the body of these instructions, “fastening” means any method of securing one part to another or to an adjacent material with fasteners in lieu of other methods, such as welding or using adhesive methods. Only those fasteners used within the system are specified in these instructions. ***Due to the varying perimeter conditions and performance requirements, perimeter and anchor fasteners are not specified in these instructions and are the responsibility of the installing contractor.**

8. FIELD STEEL ANCHORS

Steel anchors that weld to steel structure or are bolted to embeds must be line set before mullions are placed. Upstanding leg of anchors, and hence the vertical mullions, must be parallel to sidewalls of vertical mullions. Mullion spacing should be held to a location tolerance of +/- 1/32” (0.8 mm). Anchors sometimes varies per job conditions. Always refer to approved project drawings for specific job site conditions and consult your TGP project manager with project-specific questions.

9. FIELD WELDING

- a. TGP recommends experienced AWS-certified welders be used to install all field weld conditions called out in the TGP project drawings.
- b. All field welding must be adequately shielded to avoid any splatter on glass or frame components.
- c. TGP typically finishes all steel material to protect from corrosion during shipping and short term storage on site prior to installation. For powder coated finishes, it is required to grind off the finish at the expected weld location prior to welding operations. The field weld must be re-finished with a zinc rich primer (in unexposed areas) or with touch-up paint (in exposed areas) after the welding is completed. Welds should never be left unpainted or unfinished. TGP can furnish small quantities of touch-up paint as required to match the original finish.

10. SEALANTS

- a. Sealants must be compatible with all materials they are in contact with, including other sealant surfaces. Consult sealant manufacturer for recommendations relative to joint size, shelf life, compatibility, cleaning, priming, tooling, adhesion, etc.
- b. The chemical compatibility and/or adhesion of all glazing materials and framing sealants with each other and with like materials used in glass and frame fabrication must be established by the installer. This is required on every project.
- c. If required by the project specifications, it is the responsibility of the glazing contractor to submit any documentation or samples from the sealant manufacturer indicating that glass and glazing material has been tested for chemical compatibility and / or adhesion with glazing sealants. **This applies to all TGP materials in contact with any sealant.** TGP will furnish samples of these materials upon request.
- d. The implementation of the test results is the responsibility of the installing contractor, and includes material performance and recommendations for primers and substrate preparation required to obtain adhesion.

Recommended Guidelines

11. EXPANSION JOINTS

Perimeter seals shown in these instructions and in the TGP project drawings are shown at nominal size. Actual dimensions may vary due to perimeter conditions and/or difference in metal temperature between the time of fabrication and the time of installation. Design and detailing have been based on a fabrication / installation temperature of 70° F (21° C). If extreme temperatures exist at time of installation, gaps between expansion members may require slight adjustment.

Sample Elevation and Section Views

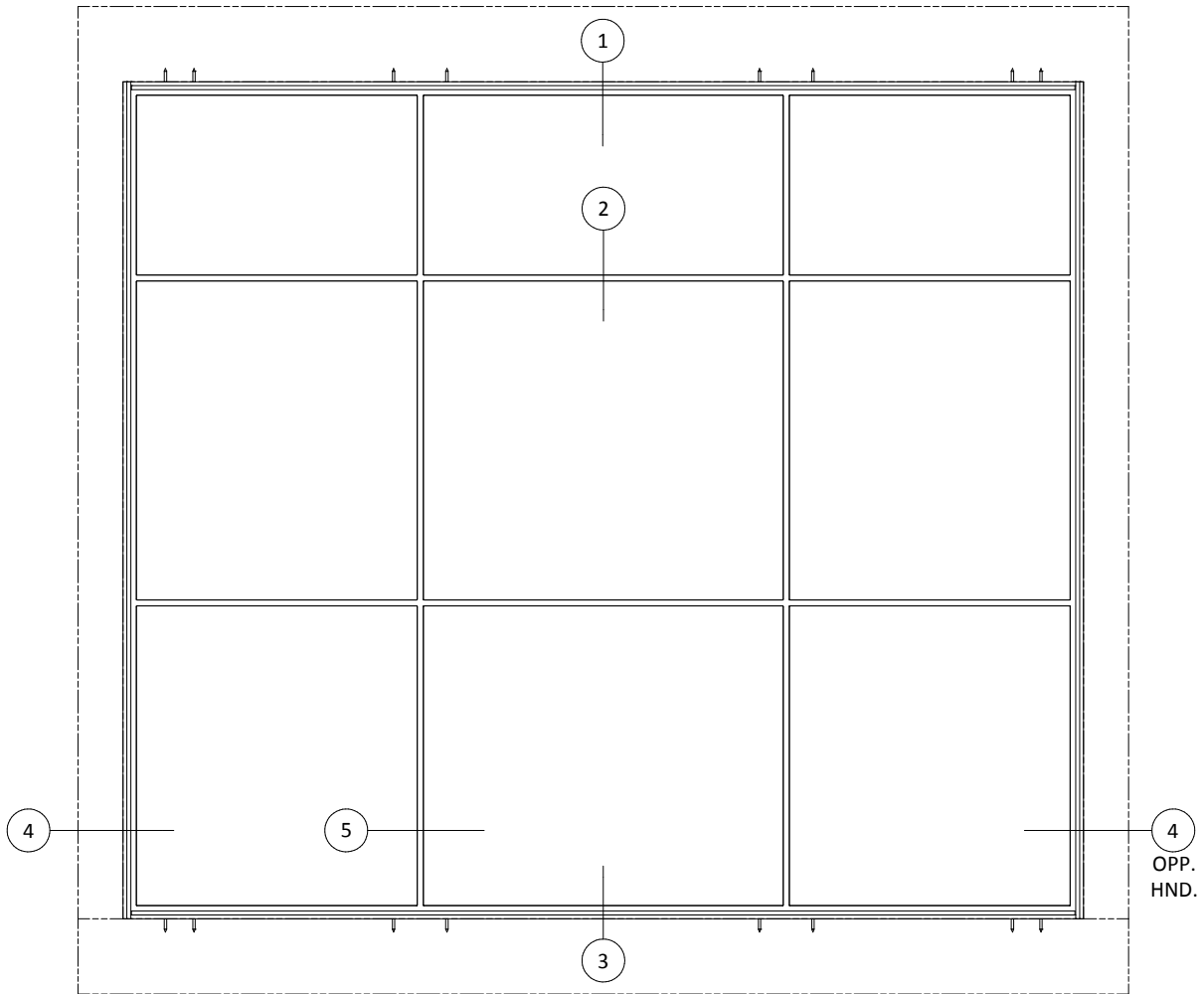
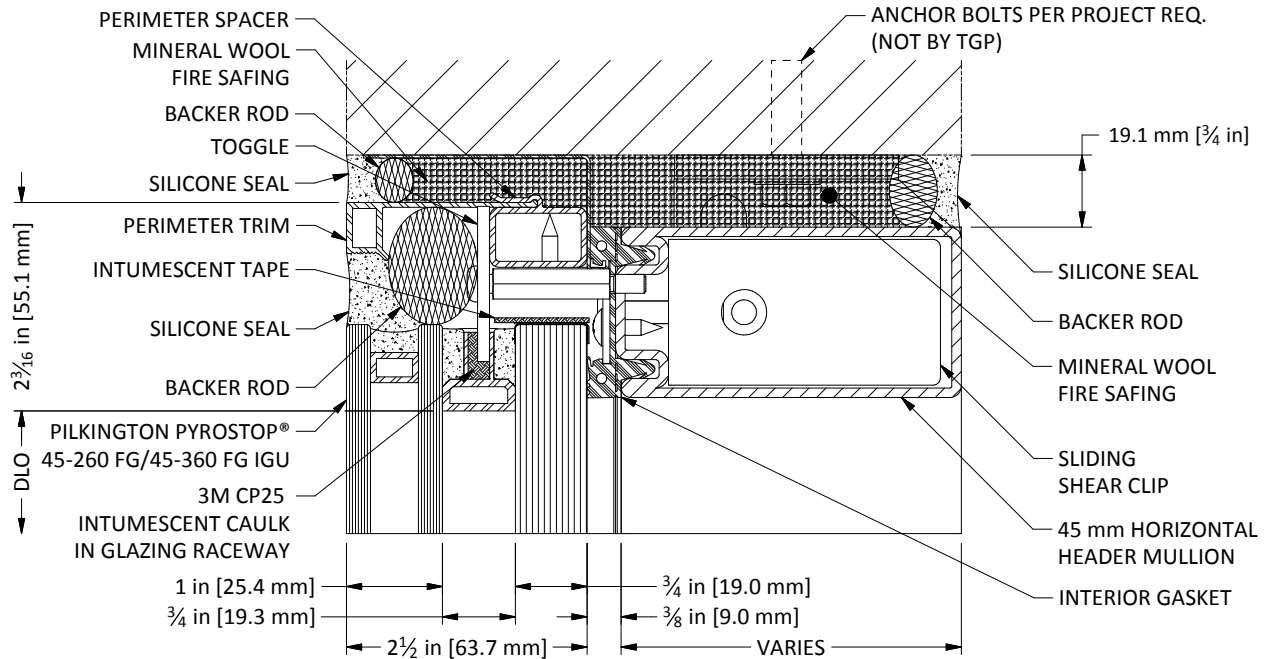
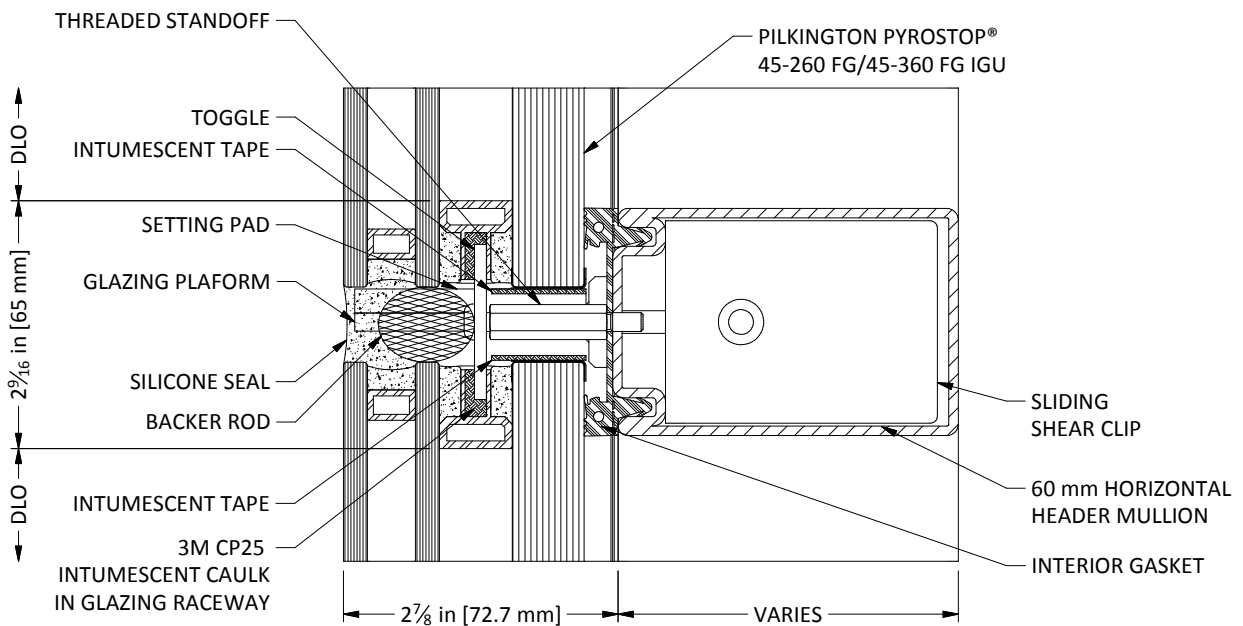

Figure 4: Sample Window Elevation with Section View References

Sample Elevation and Section Views



Section View 1: Horizontal Section at Head



Section View 2: Intermediate Horizontal Section

Sample Elevation and Section Views

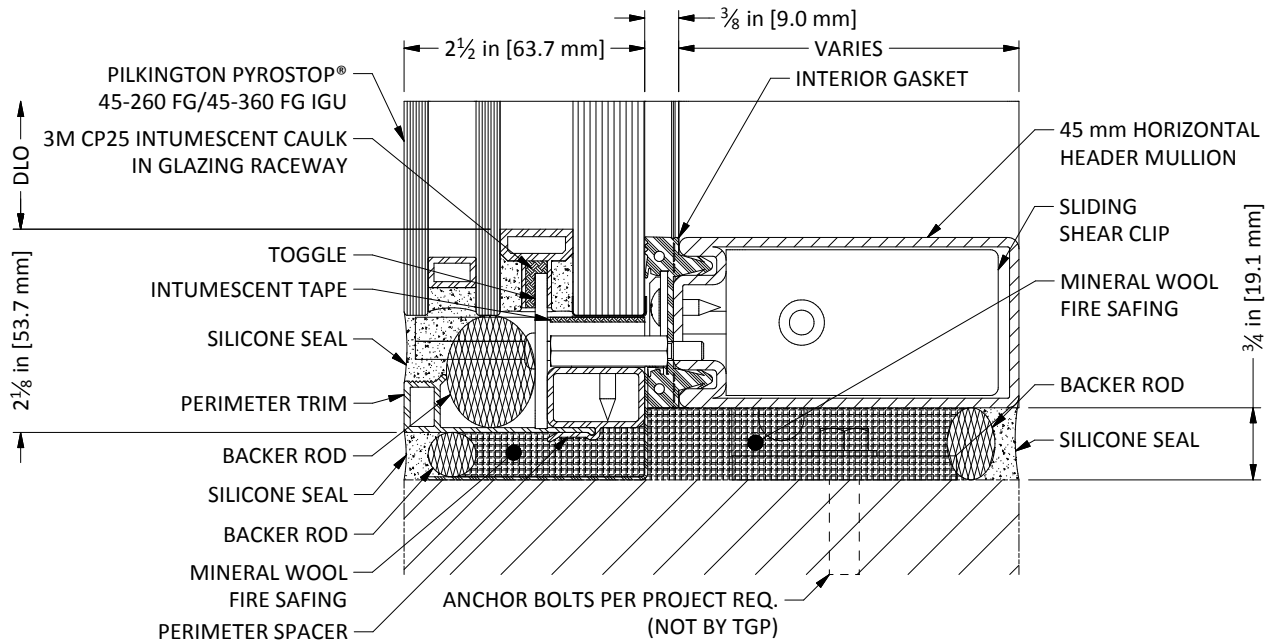

Section View 3: Horizontal Section at Sill

Sample Elevation and Section Views

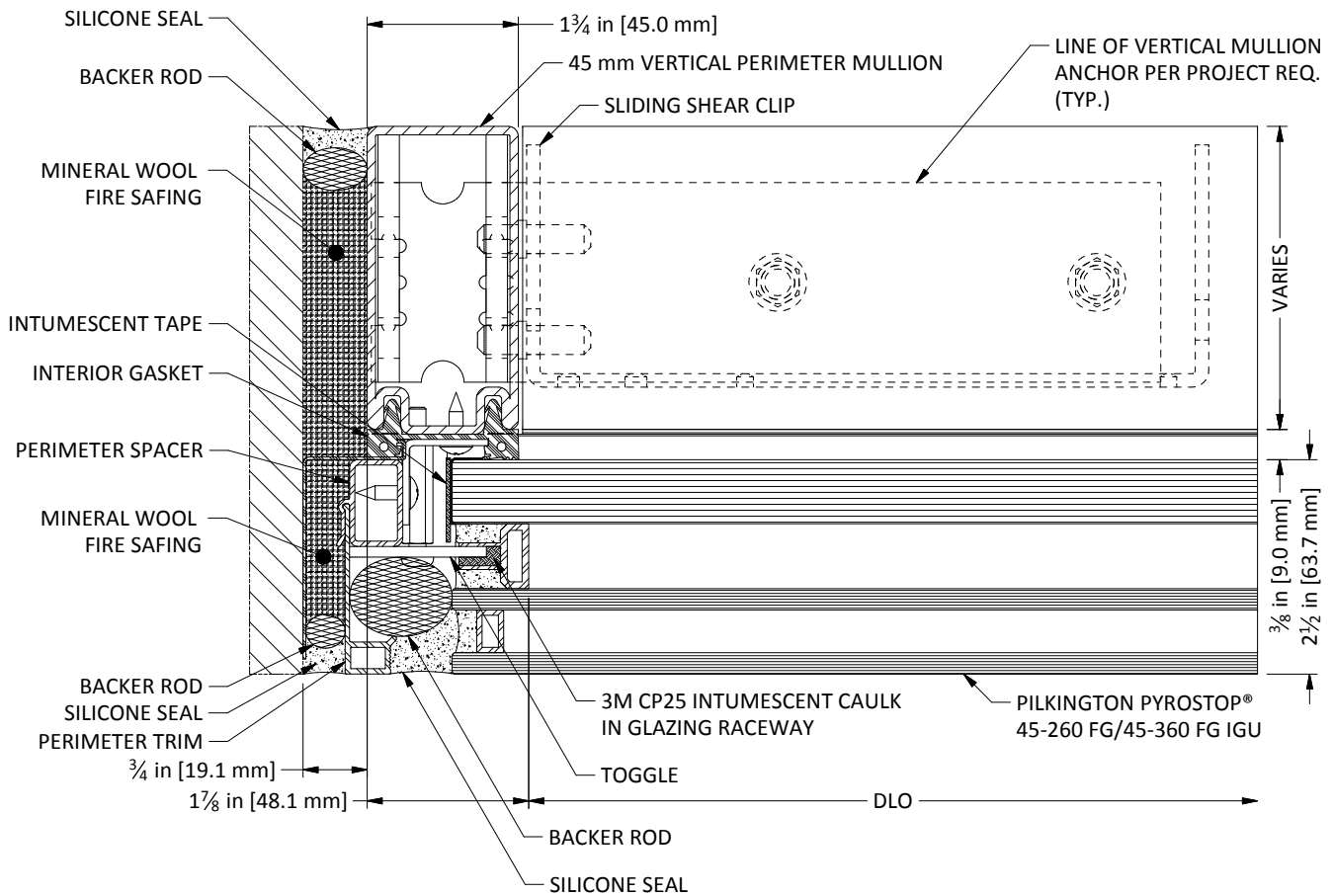

Section View 4: Vertical Section at Jamb

Sample Elevation and Section Views

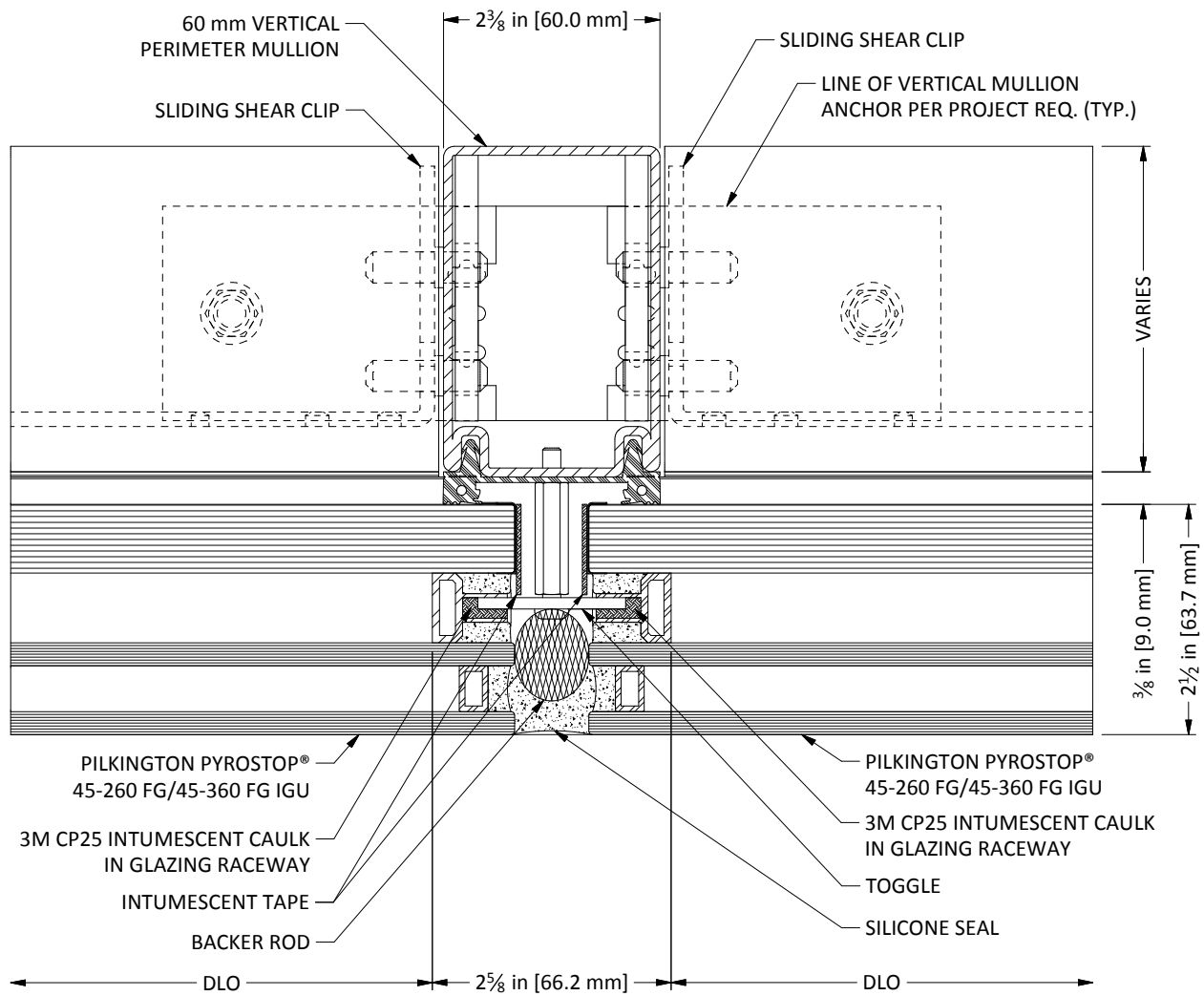

Section View 5: Intermediate Vertical Section

Profile Options

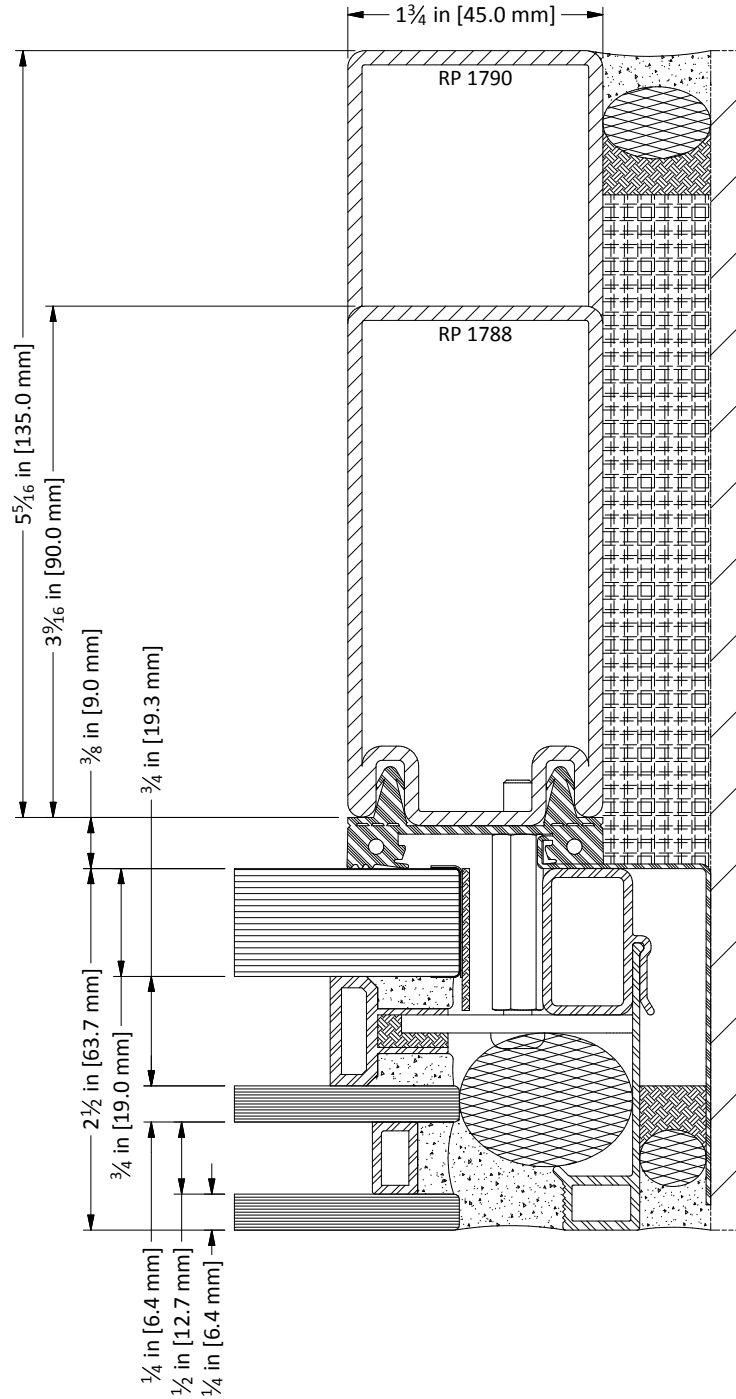

Figure 5: Perimeter Profiles

Profile Options

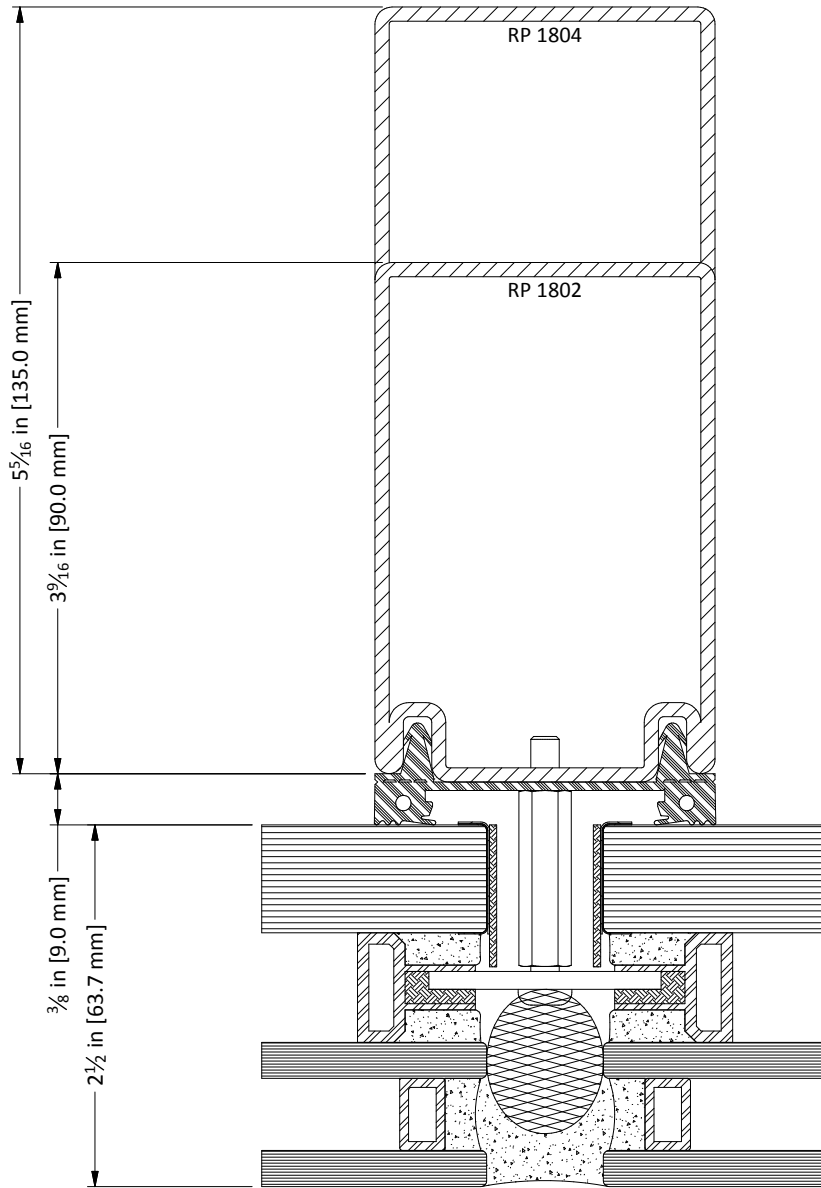

Figure 6: Intermediate Profiles

Assembly and Installation

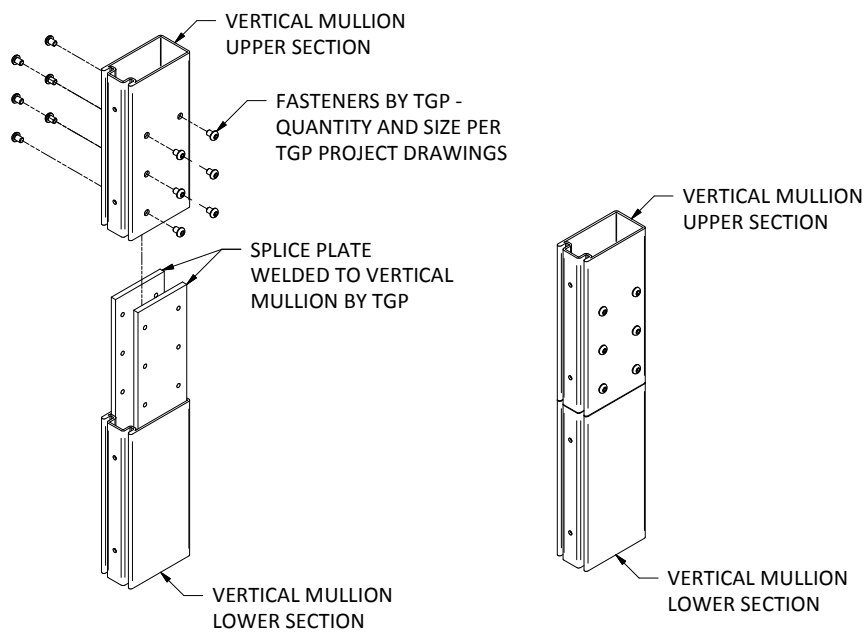

Figure 7: Fixed Splice Detail

Assembly and Installation

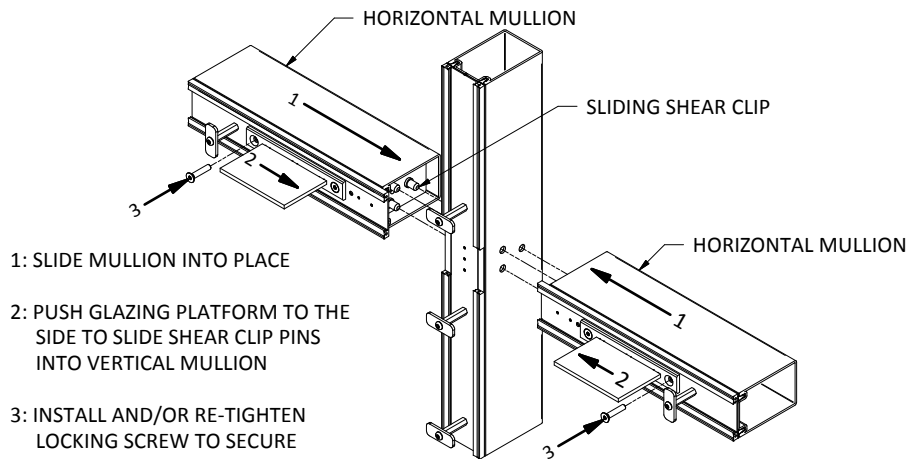

Figure 8: Recess Sliding Shear Clip into the Horizontal Mullion using Glazing Platform

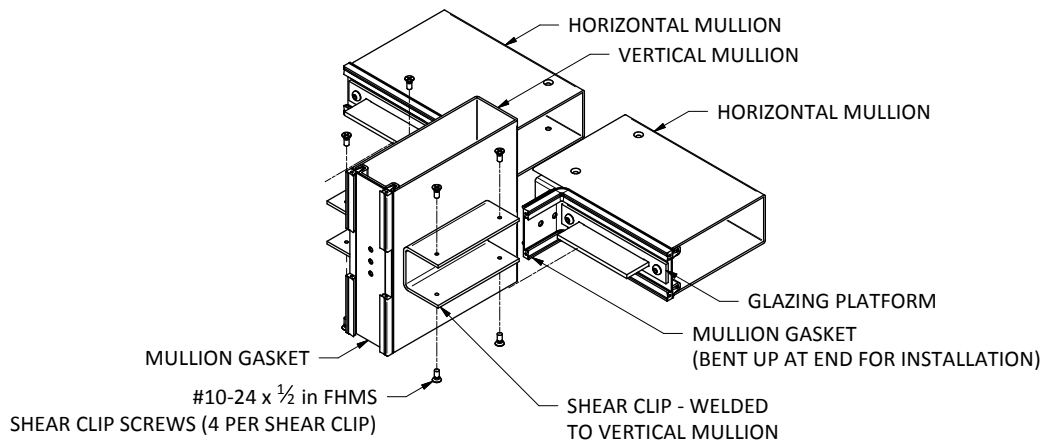

Figure 9: Welded Shear Clip Installation